

C-100MM Fast Ethernet Media Converter Modules

 perle.com/products/fast-ethernet-fiber-converter-modules.shtml

100Base-FX to 100Base-X Fiber Mode Conversion

- 100Base-FX to 100Base-X Fiber to Fiber Media Converter Module
- Multimode to multimode or multimode to single mode
- Extend multimode fiber to 120km (or more through chaining)
- Choice in SC, LC and ST fiber connector models
- Signal regeneration prevents signal degradation
- Advanced Features: [Link Pass-Through](#), Far-End Fault, loopback for each fiber connection
- High density applications with Perle [Media Converter Chassis](#)



Installed in a high density [Perle Media Converter Chassis](#), Perle's feature rich **C-100MM Fast Ethernet Fiber to Fiber** Media Converter Module enables transparent fiber extension of 100Base-FX multimode fiber to 100Base-FX multimode or 100Base-LX/EX/ZX/BX single mode fiber.

Perle's advanced features make the end to end fiber link completely transparent. This allows for more efficient troubleshooting and less on-site maintenance. In addition, a lifetime warranty and free worldwide technical support make **Perle's C-100MM Fast Ethernet Fiber to Fiber Media Converter Modules** the smart choice for IT professionals.

Whether you need to extend **multimode to multimode** or **multimode to single mode**, Perle has an extensive range of C-100MM Fast Ethernet Fiber to Fiber Media Converter Modules to meet your fiber conversion requirement.

C-100MM Fiber to Fiber Features: 100Base-FX to 100Base-X

Link Pass-Through

When enabled, the state of the receiver on one 100Base-X interface is reflected on the other 100Base-X fiber transmitter.

If disabled, the 100Base-X fiber interfaces operate independently. Far-End Fault indication on the 100Base-FX fiber interface has no effect on the other interface.

Using Link Pass-Through with Far-End Fault minimizes data loss when a fault occurs. If a fault occurs, the end devices have the indication of a failure available to making trouble shooting easier.

Far-End Fault (FEF)	<p>When enabled, the media converter transmits the Far-End Fault Indication over the fiber connection whenever a receive failure is detected. The media converter continuously monitors the fiber connection and clears the Far-End Fault Indication condition when a valid signal is received.</p> <p>When disabled, Far-End Fault Indications are not transmitted regardless of the condition of the receive signal on the 100Base-X fiber connection.</p> <p>The action the media converter takes on receiving a Far-End Fault Indication is dependent on the Link Pass Through switch setting.</p>
---------------------	--

Signal Regeneration	Signal regeneration maintains signal integrity and allows for maximum fiber to fiber connections without degradation.
---------------------	---

Cascading	Media Converters can be cascaded. Two or more media converters can be chained in a link to achieve even greater distances.
-----------	--

Pause (IEEE 802.3xy)	Pause signaling is an IEEE feature that temporarily suspends data transmission between two devices in the event that one of the devices becomes overwhelmed. The media converter is transparent to Pause frames.
----------------------	--

VLAN	The Media Converter is transparent to 802.1Q VLAN tagged packets.
------	---

Remote Loopback	The Media Converter can perform a loopback on each 100Base-X fiber interface.
-----------------	---

Indicators

Power / TST	This green LED is turned on when power is applied to the media converter. Otherwise it is off. The LED will blink slowly when in Loopback test mode.
--------------------	--

Fiber link 1 / Receive activity (LK1)	This green LED is operational only when power is applied. The LED is on when the 100Base-X link is on and flashes with a 50% duty cycle when data is received.
--	--

Fiber link 2 on / Receive activity (LK2)	This green LED is operational only when power is applied. The LED is on when the 100Base-X link is on and flashes with a 50% duty cycle when data is received.
---	--

Switches: On-Board

<u>Link Pass Through</u>	<p><i>Enabled (Default)</i> - When the state of the receiver is changed on one of the 100Base-X interfaces it is reflected on the other 100Base-X fiber transmitter.</p> <p>If disabled, the 100Base-X fiber interfaces operate independently. Far-End Fault indication on the 100Base-FX fiber interface has no effect on the other interface.</p>
---------------------------------	---

Far-End Fault (FEF)	<p><i>Enabled (default)</i> - The media converter transmits the Far-End Fault Indication over the fiber connection whenever a receive failure is detected. The media converter continuously monitors the fiber connection and clears the Far-End Fault Indication condition when a valid signal is received.</p> <p><i>When Disabled</i>, Far-End Fault Indications are not transmitted regardless of the condition of the receive signal on the 100Base-X fiber connection.</p>
----------------------------	--

Remote Loopback #1	<p>The media converter can perform a loopback on the link #1 fiber interface.</p> <p><i>Disabled (Default - Up)</i></p> <p><i>Enabled</i> - The 100Base-X receiver is looped to the 100Base-X transmitter. Link #2's fiber transmitter is taken off the interface</p>
---------------------------	---

Remote Loopback #2	<p>The media converter can perform a loopback on the link #2 fiber interface.</p> <p><i>Disabled (Default - Up)</i></p> <p><i>Enabled</i> - The 100Base-X receiver is looped to the 100Base-X transmitter. Link #1's fiber transmitter is taken off the interface.</p>
---------------------------	--

Cables

Fiber Optic Cable	Multimode: 62.5 / 125, 50/125, 85/125, 100/140 micron Single Mode: 9/125 micron (ITU-T 625)
--------------------------	--

Packet Transmission Characteristics

Bit Error Rate (BER)	<10 ⁻¹²
-----------------------------	--------------------

Environmental Specifications

Operating Temperature	0 C to 50 C (32 F to 122 F)
------------------------------	-----------------------------

Storage Temperature	minimum range of -25 C to 70 C (-13 F to 158 F)
----------------------------	---

Operating Humidity	5% to 90% non-condensing
---------------------------	--------------------------

Storage Humidity	5% to 95% non-condensing
-------------------------	--------------------------

Operating Altitude	Up to 3,048 meters (10,000 feet)
---------------------------	----------------------------------

Heat Output (BTU/HR)	11.9
-----------------------------	------

Maximum Power Consumption (watts)	3.5
MTBF (Hours)	489,076 (Calculation model based on MIL-HDBK-217-FN2 @ 30 °C)
Mechanical - Hot Swapping Card	
Edge Connector	32 pin DIN 41612 / IEC 60603-2 Type B/2 Male. First make, last break for ground and power
Card insertion and removal	Captive thumb screws enable fast insertion and removal. Can be further tightened with a screwdriver.
Product Weight	
Weight	0.15 kg, 0.33 lbs
Packaging	
Shipping Weight	0.33 kg, .73 lbs
Shipping Dimensions	203 x 38 x 152 mm, 8 x 1.5 x 6 inches
Regulatory Approvals	
	FCC Part 15 Class A, EN55022 Class A
	CISPR 22 Class A CISPR 32:2015/EN 55032:2015 (Class A) CISPR 24:2010/EN 55024:2010
Emissions	EN61000-3-2
Immunity	EN55024
	UL/EN/IEC 62368-1 CAN/CSA C22.2 No. 62368-1
	UL 60950-1 IEC 60950-1(ed 2); am1, am2 EN 60950-1:2006+A11:2009+A1:2010+A12:2011+A2:2013
Safety	CE
	EN 60825-1:2007
Laser Safety	Fiber optic transmitters on this device meet Class 1 Laser safety requirements per IEC-60825 FDA/CDRH standards and comply with 21CFR1040.10 and 21CFR1040.11.
Environmental	<u>Reach, RoHS and WEEE Compliant</u>

ECCN: 5A991

HTSUS Number: 8517.62.0020

Other

Perle Limited Lifetime Warranty

High Density Fiber Distribution from Fiber Switch Equipment at Corporate Headquarters

In this enterprise campus application, up to 19 Perle Fiber to Fiber Media Converters (Multimode to Single mode) are installed in the MCR1900 Media Converter Chassis. A remote single mode fiber enabled Ethernet switch is connected directly to the central MCR1900 Chassis. Another standalone Fiber Media Converter is connected to a remote office Fiber switch. In all cases, multimode or single-mode fiber can be used. Fiber links can be extended up to 120km using single-mode fiber.

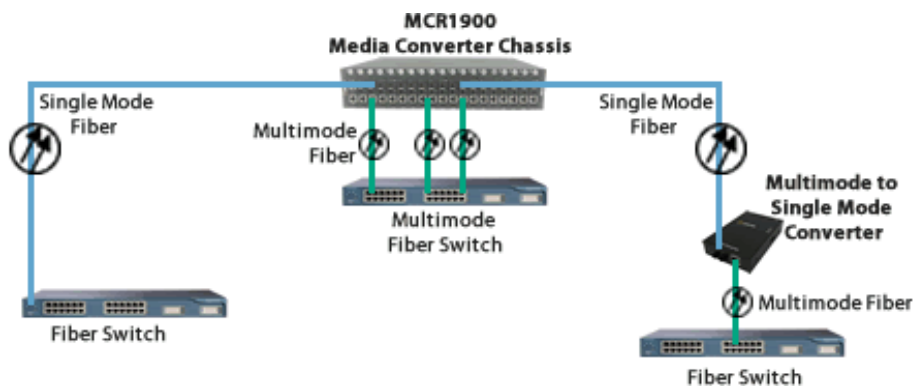

Fast Ethernet Fiber Switch to Fiber Switch

Extend the network distance between two Multimode Fiber switches

Two Fiber to Fiber Media Converters can extend the distance between Fiber Switches across a single mode fiber link up to 120km in length.

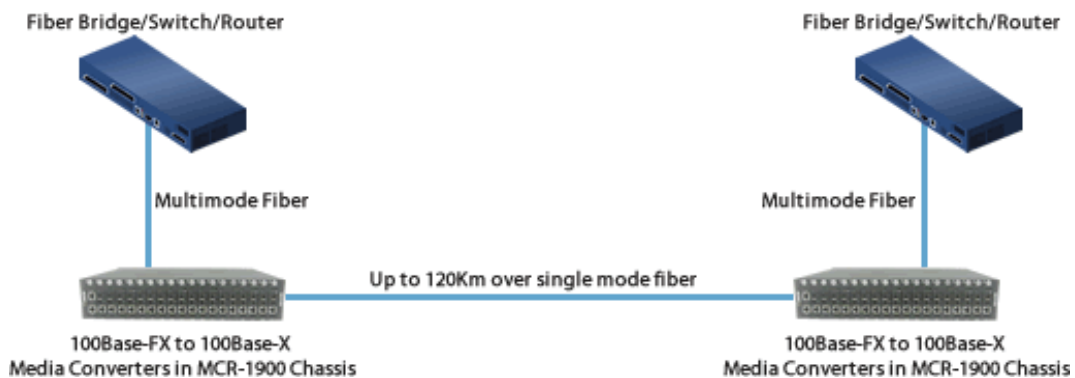

Single Mode / Single Fiber

Connect fiber ports over a single fiber strand (also referred to as “Bi-Directional” BiDi)

When Single Strand fiber is used, a pair of Single Fiber Media Converters is needed for the fiber to fiber conversion. Perle Single Fiber Media Converters are also referred to as “Up/Down” models. For example the C-100MM-S1SC20U (“Up”) and C-100MM-S1SC20D (“Down”), shown below, must be used in pairs. An “Up” must be matched with a “Down” peer to deal with transmit and receive frequencies separately.

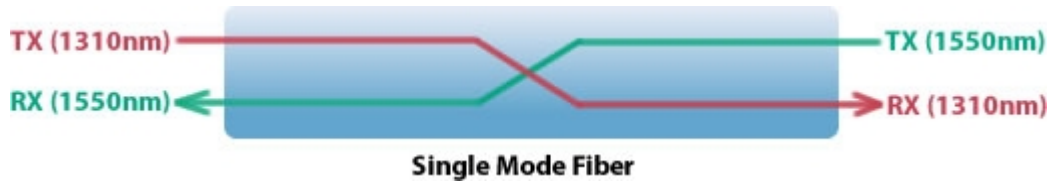

C-100MM-S1SC20UC-100MM-S1SC20D

The majority of installations for single mode fiber media converters are of the “dual connector” or “dual fiber” type where one fiber connection is used for transmit, the other for receive. These are physically “crossed” to match up the Transmit/Receive links.

However, to reduce costs, or where there are limits on available fiber, WDM technology may be utilized. WDM uses separate transmit and receive frequencies to communicate on a single fiber strand. WDM technology relies on the fact that optical fibers can carry many wavelengths of light simultaneously without interaction between each wavelength. Thus, a single fiber can carry many separate wavelength signals or channels simultaneously.

So remember, if Single Strand fiber is used, you will need an “Up” Media Converter on one side and a “Down” Media Converter on the other for fiber to fiber conversion.

Perle offers a wide variety of Single Fiber (“Up/Down”) Media Converters to connect 10BaseT, Fast Ethernet and Gigabit to single fiber. Whether you need Managed or Unmanaged, Standalone or Modular Chassis Based, 20km or 120km, Perle has the right model to meet your fiber conversion requirement.

Select a Model to obtain a Part Number - C-100MM Fast Ethernet Fiber to Fiber Media Converter Module

Model	Port	Connector	Type	Transmit (dBm)		Receive (dBm)		Power Budget (dBm)	Wavelength (nm)	Fiber Type	Operating Distance
				Min	Max	Min	Max				
<u>C-100MM-M2ST2</u>	Port 1	Dual ST	100BASE-FX	-20.0	-12.0	-31.0	-14.0	11.0*	1310	MMF	2 km (1.2 mi)
	Port 2	Dual ST	100BASE-FX	-20.0	-12.0	-31.0	-14.0	11.0*	1310	MMF	2 km (1.2 mi)
<u>C-100MM-M2SC2</u>	Port 1	Dual SC	100BASE-FX	-20.0	-12.0	-31.0	-14.0	11.0*	1310	MMF	2 km (1.2 mi)
	Port 2	Dual SC	100BASE-FX	-20.0	-12.0	-31.0	-14.0	11.0*	1310	MMF	2 km (1.2 mi)
<u>C-100MM-M2LC2</u>	Port 1	Dual LC	100BASE-FX	-20.0	-12.0	-30.0	-14.0	10.0*	1310	MMF	2 km (1.2 mi)
	Port 2	Dual LC	100BASE-FX	-20.0	-12.0	-30.0	-14.0	10.0*	1310	MMF	2 km (1.2 mi)
<u>C-100MM-S2ST20</u>	Port 1	Dual ST	100BASE-FX	-20.0	-12.0	-31.0	-14.0	11.0*	1310	MMF	2 km (1.2 mi)
	Port 2	Dual ST	100BASE-LX	-18.0	-7.0	-32.0	-3.0	14.0	1310	SMF	20 km (12.4 mi)

<u>C-100MM-S2SC20</u>	Port 1	Dual SC	100BASE-FX	-20.0	-12.0	-31.0	-14.0	11.0*	1310	MMF	2 km (1.2 mi)
	Port 2	Dual SC	100BASE-LX	-18.0	-7.0	-32.0	-3.0	14.0	1310	SMF	20 km (12.4 mi)
<u>C-100MM-S2LC20</u>	Port 1	Dual LC	100BASE-FX	-20.0	-12.0	-30.0	-14.0	10.0*	1310	MMF	2 km (1.2 mi)
	Port 2	Dual LC	100BASE-LX	-15.0	0.0	-34.0	-5.0	19.0	1310	SMF	20 km (12.4 mi)
<u>C-100MM-S2ST40</u>	Port 1	Dual ST	100BASE-FX	-20.0	-12.0	-31.0	-14.0	11.0*	1310	MMF	2 km (1.2 mi)
	Port 2	Dual ST	100BASE-EX	-5.0	0.0	-34.0	-3.0	29.0	1310	SMF	40 km (25 mi)
<u>C-100MM-S2SC40</u>	Port 1	Dual SC	100BASE-FX	-20.0	-12.0	-31.0	-14.0	11.0*	1310	MMF	2 km (1.2 mi)
	Port 2	Dual SC	100BASE-EX	-5.0	0.0	-34.0	-3.0	29.0	1310	SMF	40 km (25 mi)
<u>C-100MM-S2LC40</u>	Port 1	Dual LC	100BASE-FX	-20.0	-12.0	-30.0	-14.0	10.0*	1310	MMF	2 km (1.2 mi)
	Port 2	Dual LC	100BASE-EX	-5.0	0.0	-34.0	-3.0	29.0	1310	SMF	40 km (25 mi)
<u>C-100MM-S2ST80</u>	Port 1	Dual ST	100BASE-FX	-20.0	-12.0	-31.0	-14.0	11.0*	1310	MMF	2 km (1.2 mi)
	Port 2	Dual ST	100BASE-ZX	-5.0	0.0	-34.0	-3.0	29.0	1550	SMF	80 km (50 mi)
<u>C-100MM-S2SC80</u>	Port 1	Dual SC	100BASE-FX	-20.0	-12.0	-31.0	-14.0	11.0*	1310	MMF	2 km (1.2 mi)
	Port 2	Dual SC	100BASE-ZX	-5.0	0.0	-34.0	-3.0	29.0	1550	SMF	80 km (50 mi)
<u>C-100MM-S2LC80</u>	Port 1	Dual LC	100BASE-FX	-20.0	-12.0	-30.0	-14.0	10.0*	1310	MMF	2 km (1.2 mi)
	Port 2	Dual LC	100BASE-ZX	-5.0	0.0	-34.0	-3.0	29.0	1550	SMF	80 km (50 mi)
<u>C-100MM-S2ST120</u>	Port 1	Dual ST	100BASE-FX	-20.0	-12.0	-31.0	-14.0	11.0*	1310	MMF	2 km (1.2 mi)
	Port 2	Dual ST	100BASE-ZX	0.0	5.0	-35.0	-3.0	35.0	1550	SMF	120 km (75 mi)
<u>C-100MM-S2SC120</u>	Port 1	Dual SC	100BASE-FX	-20.0	-12.0	-31.0	-14.0	11.0*	1310	MMF	2 km (1.2 mi)
	Port 2	Dual SC	100BASE-ZX	0.0	5.0	-35.0	-3.0	35.0	1550	SMF	120 km (75 mi)
<u>C-100MM-S2LC120</u>	Port 1	Dual LC	100BASE-FX	-20.0	-12.0	-30.0	-14.0	10.0*	1310	MMF	2 km (1.2 mi)
	Port 2	Dual LC	100BASE-ZX	0.0	5.0	-34.0	-3.0	34.0	1550	SMF	120 km (75 mi)

Single Fiber Models Recommended use in pairs

Model	Port	Connector	Type	Transmit (dBm)		Receive (dBm)		Power Budget (dBm)	Wavelength (nm)	Fiber Type	Operating Distance
				Min	Max	Min	Max				
<u>C-100MM-S1ST20U</u>	Port 1	Dual ST	100BASE-FX	-20.0	-12.0	-31.0	-14.0	11.0*	1310	MMF	2 km (1.2 mi)
	Port 2	Single ST	100BASE-BX	-14.0	-8.0	-32.0	-3.0	18.0	1310/1550	SMF	20 km (12.4 mi)
<u>C-100MM-S1ST20D</u>	Port 1	Dual ST	100BASE-FX	-20.0	-12.0	-31.0	-14.0	11.0*	1310	MMF	2 km (1.2 mi)
	Port 2	Single ST	100BASE-BX	-14.0	-8.0	-32.0	-3.0	18.0	1550/1310	SMF	20 km (12.4 mi)
<u>C-100MM-S1SC20U</u>	Port 1	Dual SC	100BASE-FX	-20.0	-12.0	-31.0	-14.0	11.0*	1310	MMF	2 km (1.2 mi)
	Port 2	Single SC	100BASE-BX	-14.0	-8.0	-32.0	-3.0	18.0	1310/1550	SMF	20 km (12.4 mi)
<u>C-100MM-S1SC20D</u>	Port 1	Dual SC	100BASE-FX	-20.0	-12.0	-31.0	-14.0	11.0*	1310	MMF	2 km (1.2 mi)

	Port 2	Single SC	100BASE-BX	-14.0	-8.0	-32.0	-3.0	18.0	1550/1310	SMF	20 km (12.4 mi)
<u>C-100MM-S1SC40U</u>	Port 1	Dual SC	100BASE-FX	-20.0	-12.0	-31.0	-14.0	11.0*	1310	MMF	2 km (1.2 mi)
	Port 2	Single SC	100BASE-BX	-8.0	-3.0	-33.0	-3.0	25.0	1310/1550	SMF	40 km (25 mi)
<u>C-100MM-S1SC40D</u>	Port 1	Dual SC	100BASE-FX	-20.0	-12.0	-31.0	-14.0	11.0*	1310	MMF	2 km (1.2 mi)
	Port 2	Single SC	100BASE-BX	-8.0	-3.0	-33.0	-3.0	25.0	1550/1310	SMF	40 km (25 mi)

The minimum fiber cable distance for all converters listed is 2 meters.

*Based on use with 62.5/125 micron multimode fiber.

Copyright © 1996 - 2021 Perle. All Rights Reserved